

## Model # OG-500K-MC

Model # OG-500K-MC 3-PH 380/400/415V AC, On Grid PV Inverter 500KW System

### Product Description

#### Easy Maintenance

- Modular components make service efficient
- Convenient access to all components
- Customizable large in-floor cable gland plates make installation of DC and AC cables easy
- Integrated DC two-pole disconnect switch isolates the inverter, with the exception of the GFDI (Ground Fault Detection and Interruption) circuit, from the photovoltaic power system to allow inspection and maintenance

#### Safety & special compliance

- Seismic Zone 4 compliant (Optional)
- Built in DC disconnect Switch and AC Breaker
- Protective covers over exposed power connections

#### Full data display and communications

- Customization LCD display all the inverter operation message
- Bright LED indicators imply system status at a glance
- PC software for remote monitoring and system troubleshooting
- High speed RS-232, RS-485 communications port.

#### Key Features

- 25years of design life
- IP42 (optional) IP21 containment system
- Redundant control circuit design for more reliability
- MPPT efficiency: 99.9%
- Overall efficiency: 98.1%
- Unique zero voltage ride through (ZVRT) function
- Advanced DSP control systems
- Supports SVG function, realization of power reactive compensation at night
- Supports variety of communication protocols
- 5 Years warranty extendable to 10 Years



### Applicable Standards

- ❖ ISO9001 & ISO14000
- ❖ Compliance to RoHs
- ❖ CE
- ❖ IEC62109, VDE 0126-1-1, VDE-AR-N4105, EN50178, VDE0126-1-1, EN61000-3-2 EN61000-6-2, EN61000-6-3 ENEL-Guide, G59, G83, RD1663AS4777, AS/NZS 3100, CGC CE

## Model # OG-500K-MC

### Specification

MODEL	OG-500K-MC
<b>INPUT</b>	
Max. DC input power	550KW
Max.DC input voltage	1000Vdc
MPPT tracking voltage range	450~850Vdc
Number of MPPT tracking	1
Max. input current	1200A
<b>OUTPUT</b>	
Rated output power	500KW
Rated output voltage	400Vac
AC output topology	3Ph+N+PE
Output voltage range	(1±15%) x Normal AC Voltage (adjustable ±5%,±10%,±15%,±20%)
Gird frequency range	50/60Hz(±4.5Hz), (adjustable)
Rated AC output current	722A
Max. AC output current	794A
Power factor (cosΦ)	1 ( 0.9 leading – 0.9 lagging) (adjustable)
Total harmonic current distortion (THDi)	<3%
<b>SYSTEM FEATURES</b>	
Max. efficiency	>98.1%
Euro efficiency	>97.9%
MPPT efficiency	>99%
Standby(night time) losses	<10W
Cooling	Forced air cooling
Communication interface	RS485, external Ethernet (optional)
<b>ENVIRONMENTAL</b>	
Operating temperature	-40.0 to 55.0 °C
Humidity range	0~95% (non-condensing)
Altitude	3000m

## Model # OG-500K-MC

<b>Noise level</b>	<60dB
<b>Protection rating</b>	IP20/ IP42(optional)
<b>PHYSICAL</b>	
<b>Dimension W×H×D (mm)</b>	1600×935×2200
<b>Net Weight (kg)</b>	2800
<b>STANDARDS</b>	
<b>Grid Code</b>	NB/T32004, VDE-AR-N 4105, IEC 61727
<b>Safety/TUV</b>	IEC62109-1, IEC62109-2
<b>EMC</b>	EN 61000-6-2 , EN 61000-6-3, EN 61000-6-4, EN 61000-3-11, EN 61000-3-12
<b>Quality Standards</b>	ISO9001:2015, ISO14001, RoHs

## System Layout

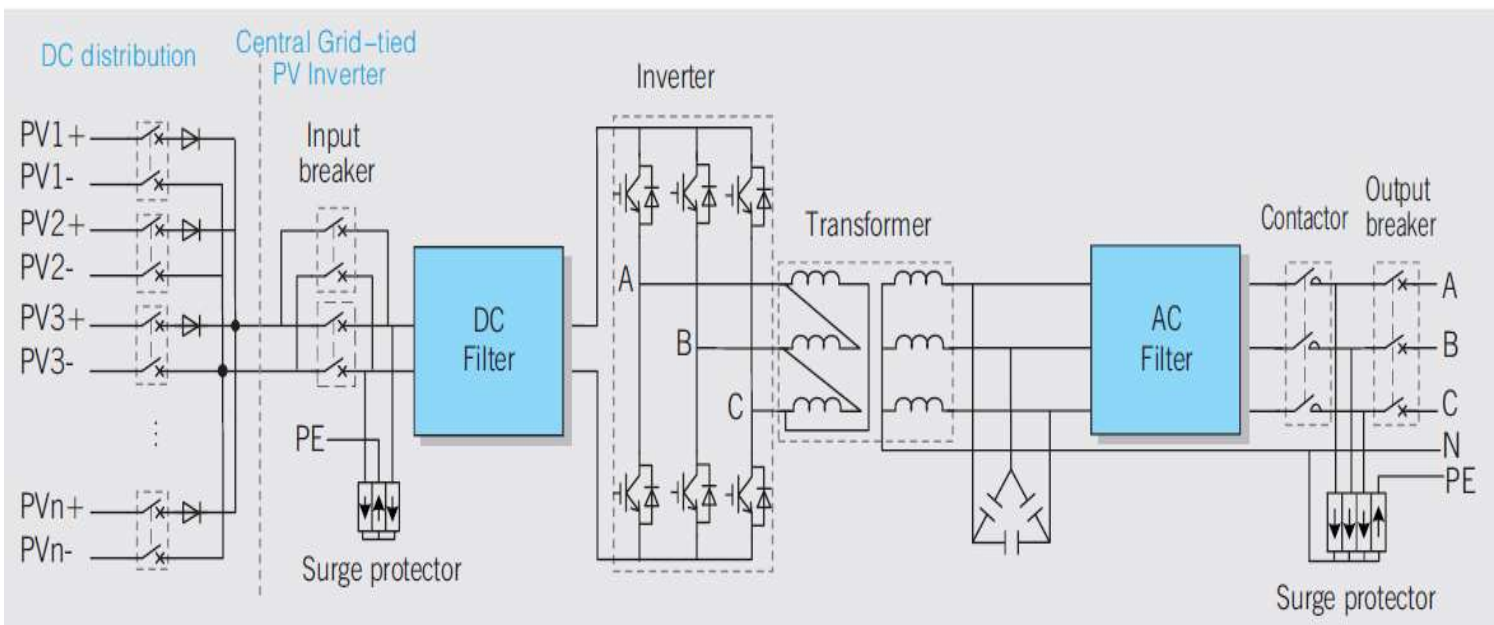

For OG250K-MC, n=10