



Product Description:

OG-20-30K-TM String Inverter Series is the ideal solution for commercial & industrial usage. Parallel capability upto 100nos allows to simply up the scalability and enhancing the overall plant capacity. With the characteristics of dual/tripple independent input sections with two/three independent MPP trackers, wide MPPT tracking range, True three phase transformer-less design, IP65 harshest industrial grade protection level, convectional cooling system and embedded RS485, WIFI and optional SNMP interface, it forms Magnizon Trio String Inverter an ideal solution for medium and large PV Power Station.

Key Features

- ❖ From 20KW/30KW
- ❖ Wide PV input voltage range
- ❖ Rapid MPPT tracking technology
- ❖ 25years of design life
- ❖ IP65 protection degree, suitable for outdoor installation, reducing
- ❖ Redundant control circuit design for more reliability
- ❖ Unique low voltage ride through (LVRT) function
- ❖ Advanced DSP control systems
- ❖ Supports SVG function, realization of power reactive compensation at night
- ❖ Supports variety of communication protocols
- ❖ 5years warranty extendable to 10years
- ❖ Superior PV energy harvest
- ❖ Transformers less design with higher operation efficiency
- ❖ Excellent natural thermal design
- ❖ High over load capability under most ambient conditions

Full data display and communications

- ❖ Customization LCD display all the inverter operation message
- ❖ Bright LED indicators imply system status at a glance
- ❖ PC software for remote monitoring and system troubleshooting , iOS & Android real time power monitoring software (life time free of cost)
- ❖ High speed RS-232, RS-485 communications port.

Cost advantages

- ❖ Transformer less design cutting down the cost
- ❖ Light weight and small dimension, reducing shipping cost
- ❖ IP65 protection degree, suitable for outdoor installation, reducing
- ❖ Construction cost
- ❖ Low maintenance expense

Applicable Standards:

- ❖ ISO9001: 2015, ISO14001:2015
- ❖ Compliance to RoHs & CE
- ❖ IEC62109-1, IEC62109-2, NBT/T32004, EN61000-6-2/3/4, EN61000-3-11/12
- ❖ VDE-AR-N 4105, IEC61727, G59, G83, RD1663AS4777

Specifications:

MODEL	OG-20K-DM	OG-30K-TM
INPUT (DC)		
Max. DC input power	24000W	36000W
Max.DC input voltage	1000Vdc	
Max. Input Current	46A (2x23A)	69A (3x23A)
MPPT tracking voltage range	200~950Vdc	
MPPT operating voltage range (full load)	480-850V	
Min. / start DC voltage	200 / 250Vdc	
Number of MPPT tracking	2	3
Maximum number of PV strings	4(2/2)	6(2/2/2)
OUTPUT (AC)		
Rated AC active power	20KW	30KW
Max. AC active Power (Pf=1)	22KW	32KW
Max. AC apparent power	22KVA	32KVA
Rated output voltage	380/400/415Vac	
AC output topology	3Ph+N+PE	
Output voltage range	(1±15%) x Normal AC Voltage (adjustable ±5%,±10%,±15%,±20%)	
Gird frequency range	50/60Hz(±4.5Hz), (adjustable)	
Max. AC output current	30A	48A
Power factor (cosΦ)	(0.8 leading – 0.8 lagging) (adjustable)	
Total harmonic current distortion (THDi)	<3%	
DC Current Injection	<0.5In	
Protection devices		
Input DC switch	YES	
Anti-islanding protection	YES	
AC overcurrent protection	YES	
AC short circuit protection	YES	
DC reverse connection	YES	

Model # OG-20-30K-TM series, 3-ph 400V AC, Grid Tie string inverters with built in 3xMPPT controllers

Anti-surge protection	YES
Insulation resistance detection	YES
Leakage current protection	YES
Intelligent reactive power regulator	YES
PID	YES
SYSTEM FEATURES	
Topology	Transformer less
Max. efficiency	>98.8%
Euro efficiency	>98.4%
MPPT efficiency	>99%
Standby(night time) losses	<10W
Front Panel	LED/LCD Display
Cooling	Natural Cooling
Communication interface	RS485, USB, Ethernet, WIFI(optional), GPRS(optional)
Warranty	5years(optional 10/15/20years)
ENVIRONMENTAL	
Operating temperature	-25.0 to 60.0 °C
Humidity range	0~99% (non-condensing)
Altitude	4000m
Noise level	<30dB
Protection rating	IP65
PHYSICAL	
Dimension W×L×D (mm)	550mm*715mm*284mm
Net Weight (kg)	53Kgs
STANDARDS	
Grid Code	NB/T32004, VDE-AR-N 4105, IEC 61727
Safety/TUV	IEC62109-1, IEC62109-2
EMC	EN 61000-6-2 , EN 61000-6-3, EN 61000-6-4, EN 61000-3-11, EN 61000-3-12
Quality Standards	ISO9001:2015, ISO14001, RoHs

Model # OG-20-30K-TM series, 3-ph 400V AC, Grid Tie string inverters with built in 3xMPPT controllers

Efficiency (%):

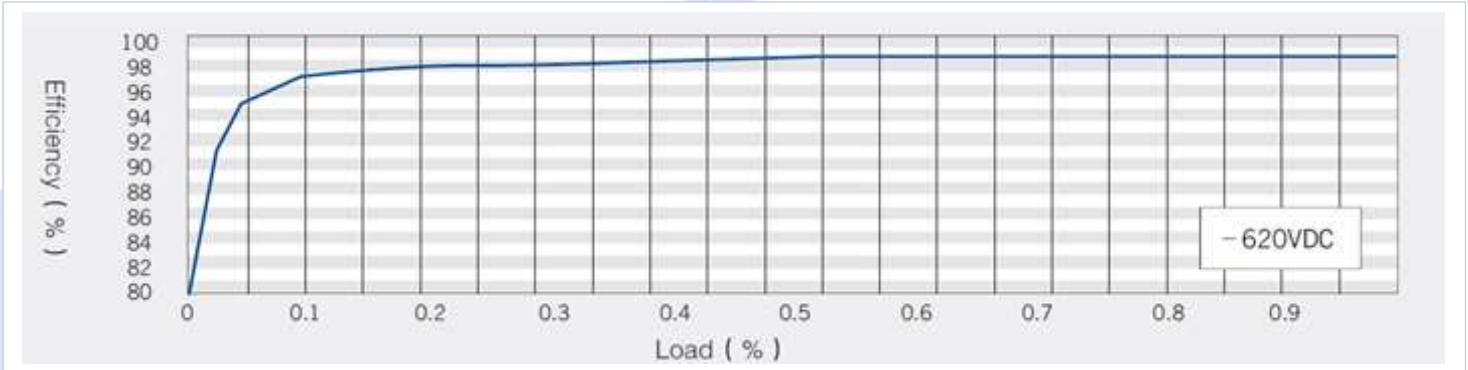

Control Scheme:

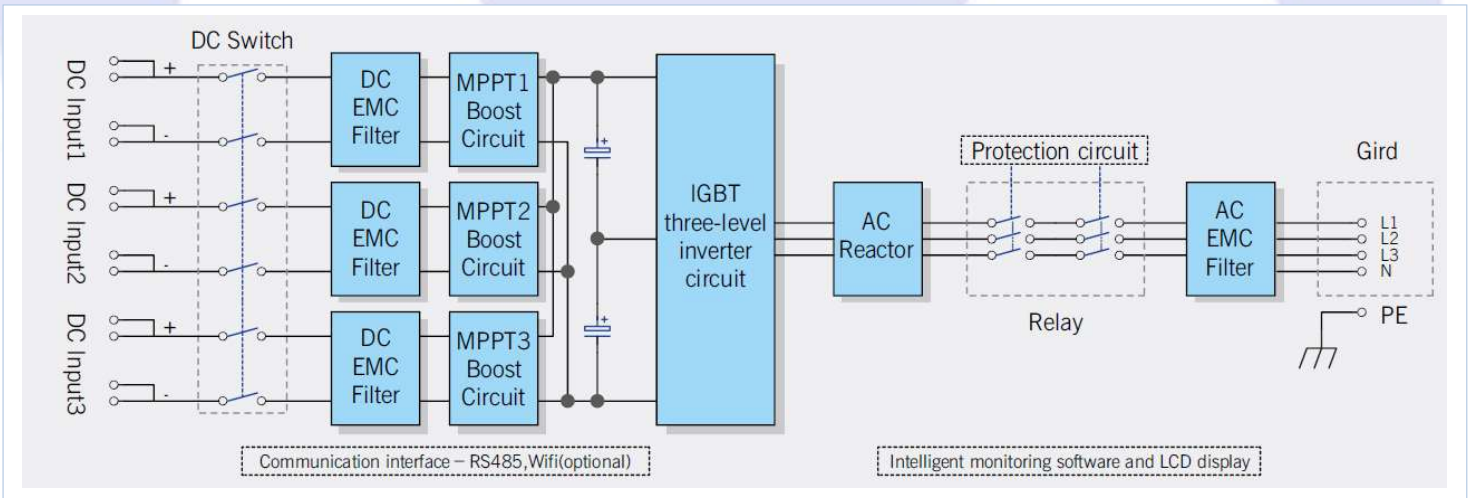

Bottom view:



Copyright © 2012 MAGNIZON POWER SYSTEMS. All rights reserved. All trademarks are the sole property of their respective owners. MAGNIZON POWER SYSTEMS has a policy of continuous improvement. Specifications are subject to change without notice. Photos may differ slightly from final products.